

Product Description

- Flush mount mantel with recessed firebox design provides the look of an authentic fireplace.
- Requires only minutes to assemble and install – one person, one trip.
- Stone-look and pre-primed MDF models available.
- Attractive, durable stone-look mantel offers a transitional design to suit contemporary or traditional décors.
- Pre-primed MDF mantel can be painted to complement any colour scheme.
- MDF mantel also features a cream marble-look or black granite-look surround.
- Mounting brackets included on all models.



Pre-primed MDF mantel with cream marble-look surround (BM39-CM) and BF39DXP firebox.



Pre-primed MDF mantel with black granite-look surround (BM39-BG) and BF39DXP firebox.



Stone-look mantel (BM39-STN) and BF39DXP firebox.

Specifications, finishes and dimensions are subject to change. Details given should be taken as a guide only. Protected by one or more of the following U.S. Patents: 6,050,011, 6,269,567, 6,190,019, 6,564,485, 5,642,580, 6,615,519, 6,363,636, 6,047,489, 6,718,665, 6,350,498, 6,162,047, 6,385,881 and Canadian Patents: 2,175,442, 2,310,367, 2,310,073, 2,204,106, 2,310,362, 2,310,414, 2,262,338. Other patents pending.

Specifications

Model	Description	Dimensions	Weight
BM33-CM	Pre-primed MDF mantel with cream marble-look surround – for 33" built-in firebox (BF33STP/DXP).	62.5" W x 51.75" H x 7.4" D	80 lb / 36 kg
BM33-BG	Pre-primed MDF mantel with black granite-look surround – for 33" built-in firebox (BF33STP/DXP).	62.5" W x 51.75" H x 7.4" D	80 lb / 36 kg
BM33-STN	Stone-look mantel with matching surround – for 33" built-in firebox (BF33STP/DXP).	60.8" W x 49.8" H x 9.8" D	118 lb / 53.6 kg
BM39-CM	Pre-primed MDF mantel with cream marble-look surround – for 39" built-in firebox (BF39STP/DXP).	68.5" W x 56" H x 7.4" D	90 lb / 40.5 kg
BM39-BG	Pre-primed MDF mantel with black granite-look surround – for 39" built-in firebox (BF39STP/DXP).	68.5" W x 56" H x 7.4" D	90 lb / 40.5 kg
BM39-STN	Stone-look mantel with matching surround – for 39" built-in firebox (BF39STP/DXP).	66.8" W x 53.6" H x 9.8" D	128 lb / 58.2 kg

Labor-Saver Assembly and Installation

BM33-STN BM39-STN

Stone-Look Labor-Saver Mantel

- Four-piece mantel design for simple assembly
- Wall brackets make installation quick and easy

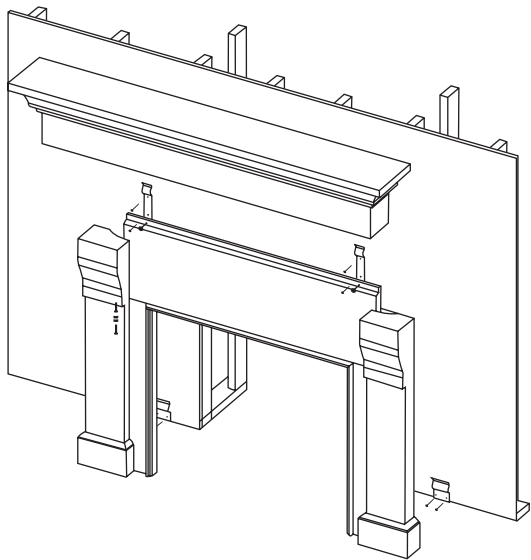

BM33-CM / BM33-BG BM39-CM / BM33-BG

Pre-primed MDF Mantel with Surround

- Five-piece mantel design and three-piece surround for simple assembly
- Wall brackets make installation quick and easy

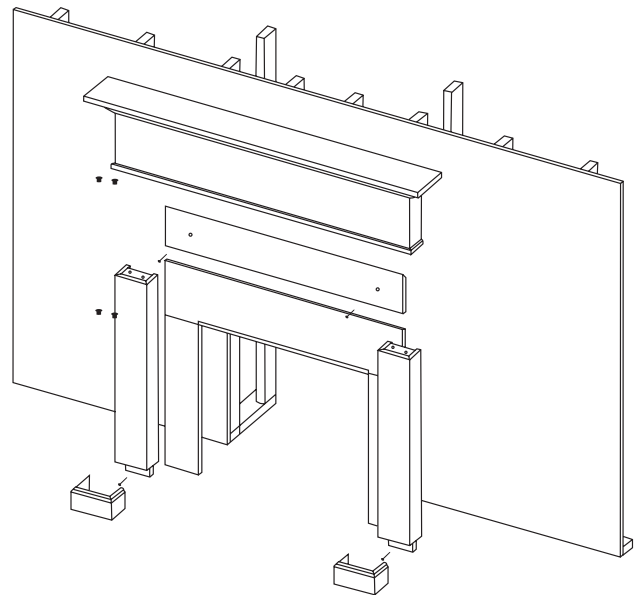

Specifications, finishes and dimensions are subject to change. Details given should be taken as a guide only. Protected by one or more of the following U.S. Patents: 6,050,011, 6,269,567, 6,190,019, 6,564,485, 5,642,580, 6,615,519, 6,363,636, 6,047,489, 6,718,665, 6,350,498, 6,162,047, 6,385,881 and Canadian Patents: 2,175,442, 2,310,367, 2,310,073, 2,204,106, 2,310,362, 2,310,414, 2,262,338. Other patents pending.